

HERO

MAKE INNOVATION

- S2300
5 Gallon Tri Mixer

OPERATOR MANUAL

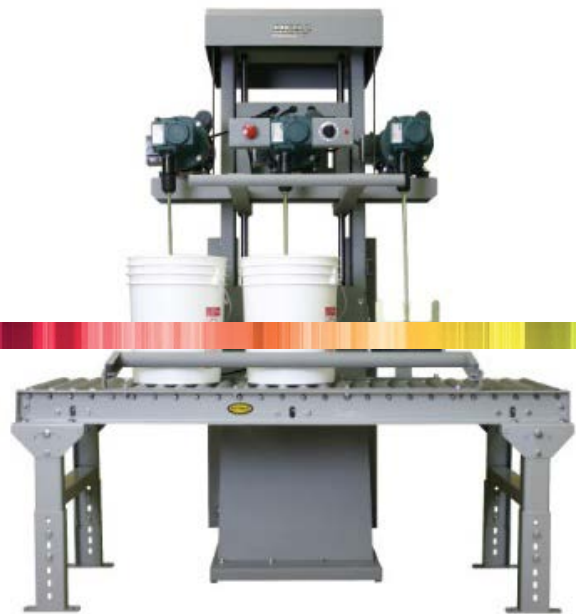

TABLE OF CONTENTS

TABLE OF CONTENTS	2
WARRANTY	3
SAFETY WARNINGS	4
GROUNDING INSTRUCTIONS	4
GENERAL INFORMATION	4
SETUP	7
Package Inspection	7
Installation	7
Levelling	7
OPERATING INSTRUCTIONS	8
CARE & CLEANING	8
Maintenance	8
Cleaning	8
SERVICE INSTRUCTIONS	8
Paddle Replacement	8
TROUBLESHOOTING	9
SPECIFICATIONS	9
Overall Dimensions	9
Electrical Rating	9
Container Size Accommodation	9

WARRANTY

HERO offers a two year parts warranty and one year labor warranty on all of its shakers and mixers. The warranty entitles the owner to parts replacement at no charge. The parts warranty is valid for any necessary replacement, whether caused by material, workmanship defect or simple wear, except as noted below.

Electric motors, timers and pneumatic motors warranted for twelve (12) months only.

The warranty is applicable to the original owner only and is non-transferable. The equipment must be operated and maintained in accordance with all instructions, precautions and warnings contained in the product manual. For the purpose of this warranty, damage caused by accident, abuse, improper cleaning or lack thereof, or improper operation, is not covered. Cleaning and general maintenance is the responsibility of the owner/operator and is not covered by the warranty.

HERO's liability is limited to the replacement of parts found to be defective or worn and does not include damage or other expenses of any kind incurred in connection with the purchase and use of the product.

All parts required for warranty service are invoiced to the client, with credit provided upon submission of a valid warranty claim. A valid claim lists the model number, serial number, date of installation, lists all parts used and provides for parts installation charges.

Major parts replacement may require the return of defective parts. If uncertain, contact HERO for further instruction. All returns must be authorized and no return will be accepted without a Return Merchandise Authorization (RMA) number.

All warranty work requests or claims must be directed to HERO Customer Service at any of the following:

Canadian Mail: 720 Eaton Way • Delta, BC • Canada • V3M 6J9

US Mail: P.O. Box 75 • Custer, WA • USA • 98240-0075

Phone: 604-522-6543

Fax: 604-522-8735

Email: customercare@hero.ca

Help Desk: 800-494-4376, option 1

Parts warranty includes shipping via a carrier and service type compatible with the nature of the equipment failure and as determined by an authorized HERO Customer Service Representative. When expedited delivery is not warranted, the customer may request and pay for the difference between such service and HERO's standard shipping method.

The labor warranty on units covers on-site and travel labor to and from the customer's location. An authorized HERO Customer Service Representative must approve all warranty repairs before any work is performed.

SAFETY WARNINGS

- Each bucket backstop has a switch that will activate the stirring motor when a bucket is in place.
- Mixing or cleaning with flammable substances could cause an explosion.
- To avoid electrical shock, unplug machine before servicing.
- To reduce the risk of electrical shock or injury, use indoors only.
- The mixer is designed to operate only when the carriage is lowered and a bucket is in place. Do not attempt to alter the electrical interlocks.

GROUNDING INSTRUCTIONS

- This product should be grounded. In the event of an electrical short circuit, grounding reduces the risk of electric shock by providing an escape wire for the electric current. This product is equipped with a cord having a grounding wire with an appropriate grounding plug. The plug must be plugged into an outlet that is properly installed and grounded in accordance with all local codes and ordinances.
- **WARNING** - Improper installation of the grounding plug can result in a risk of electric shock. When repair or replacement of the cord or plug is necessary, ensure the grounding conductor is connected to the grounding terminals. The wire insulation having an outer surface that is green with or without yellow stripes is the grounding wire.
- Check with a qualified electrician or serviceman if the grounding instructions are not completely understood, or if in doubt as to whether the product is properly grounded. Do not modify the plug provided; if it will not fit the outlet, have the proper outlet installed by a qualified electrician.
- This product is for use on a nominal 240-volt circuit. Only connect the product to an outlet having the same configuration as the plug. Do not use an adapter with this product.

GENERAL INFORMATION

- Forcing the mechanical timer back to the zero position will cause premature failure of the mechanical timer
- When not in use for extended periods of time, ensure that the machine, including its power cord, is properly stored in a way that it is protected from damage.
- The motors of the mixer are equipped with automatic thermal overload devices. In the event a motor stops running due to overload, it will automatically reset itself when the motor returns to normal operating temperature.

IDENTIFICATION

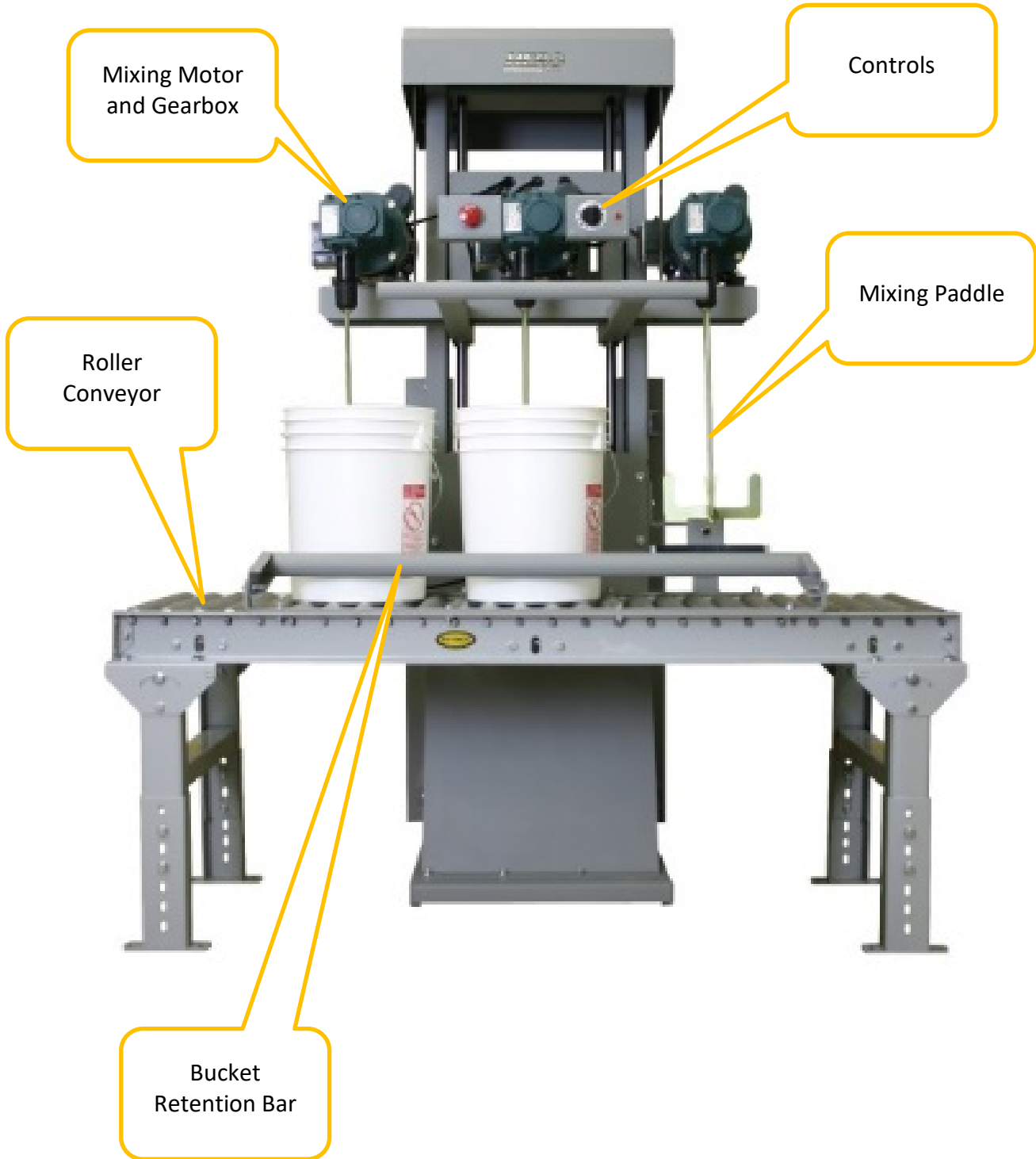

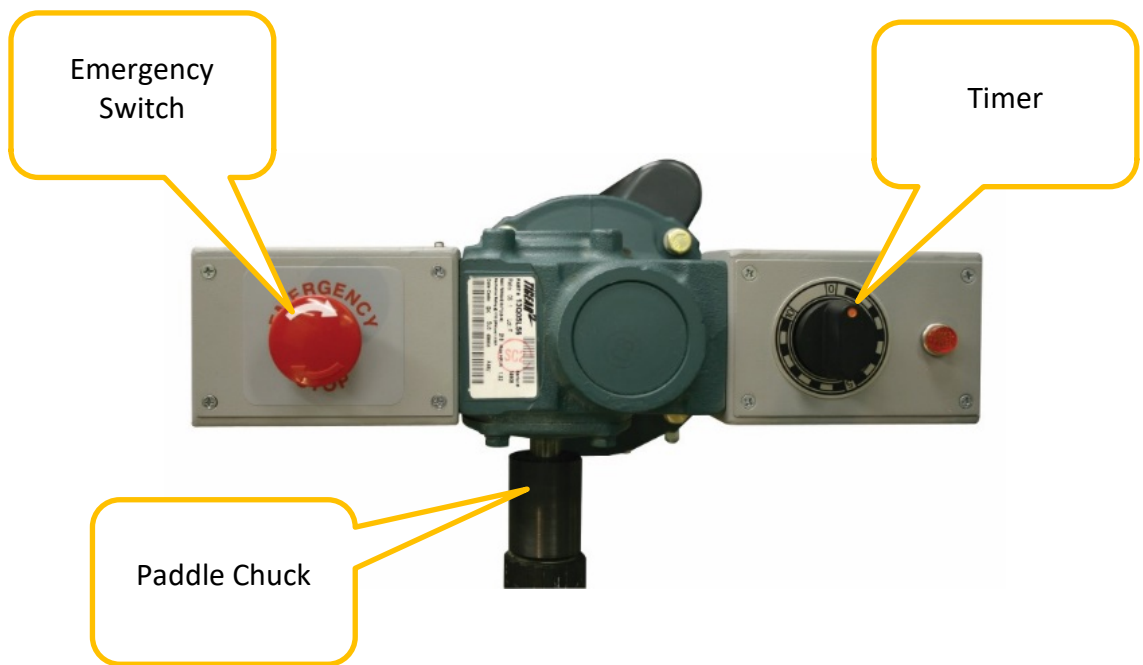

SETUP

Package Inspection

Visually inspect the product upon receipt for any external or concealed damage. Should any damage be noted, a hidden damage report must be filed by the consignee. This applies only to damage discovered within 24 hours of delivery. Do not delay in filing the report form.

Contact HERO's Customer Service Department at 1-800-494-4376 or customercare@hero.ca before proceeding, if damage is found.

Installation

Refer to the **Identification** section of this manual to assist with part determination and placement.

1. Using a socket wrench, unbolt the four lag bolts which are located at each end of the main carriage handle. These bolts and clamps secure the main carriage handle to the front shipping frame. The bolts are identified by red paint markings.
2. Using a socket wrench, unbolt the four lag bolts which are located on the front shipping frame. The bolts are identified by red paint markings.
3. Using a socket wrench, unbolt the four lag bolts, which are located at each corner of the machines, platform. These bolts secure the machine to the shipping skid. They are identified by red paint markings.
4. A fork truck must be used to remove the machine from its skid. There are angle brackets attached to the machine uprights for ease of fork truck removal. Any other method of removal could cause injury to yourself, or others, and possible damage to the machine.
5. Using a socket wrench, unbolt the two hex bolts which are located on the counter weight columns. These bolts secure the counter weights to the columns to prevent movement during shipping. They are identified by red paint markings

Levelling

Refer to the **Identification** section of this manual to assist with part determination and placement.

6. When leveling, check for left-to-right movement, as the variance of different flooring may require one side of the machine to be positioned higher or lower than the other. Using a socket wrench, adjust the four leveling hex bolts which are located at each corner of the machine platform. After adjusting, ensure the lock nuts are tightened.

NOTE: With the machine properly levelled, it will not walk or vibrate excessively during operation. If the mixer does walk or vibrate excessively, check the levelling and readjust the levelling studs as needed.

OPERATING INSTRUCTIONS

- **EMERGENCY STOP:** Push button in to shut power off. Turn clockwise to release the button and turn power on.
- **TIMER:** Set timer to desired mixing time. If you stop mixing before the timer runs out, do not turn the timer back to zero as this can cause premature timer failure. You may also choose to set your timer after the main carriage has been lowered, and the paddles are fully submerged.
- **START:** With timer set, lower the main motor carriage. The mixing paddles will turn on once the carriage switch has been activated and a bucket is present. At this point the paddles will be approximately half way into the bucket.
- **STOP:** Timer runs out or by raising the motor carriage. The mixing paddles will stop once lifted more than half way out of the bucket.

➤ CARE & CLEANING

a. Maintenance

- This mixer is designed for maintenance-free operation. For technical support, contact HERO Customer Service at 800-494-4376 or customercare@hero.ca.



a. Cleaning

- No special cleaning provisions are required; however, should any paint spill or spatter occur, the mixer should be disconnected from power prior to cleanup. Only mild detergents should be used for cleaning as aggressive cleaners or solvents may damage the finish. Following cleaning, reconnect the mixer to its power source.

SERVICE INSTRUCTIONS

Service shall be carried out by authorized service personnel. For technical support, contact HERO Customer Service at 800-494-4376 or customercare@hero.ca.

CAUTION: Remove power to the mixer prior to exposing or accessing any internal components.

Paddle Replacement

7. Unplug the power cord to remove all power from the mixer.
8. While holding the paddle from rotating with one hand, use the other to loosen the chuck.
9. Lower and remove the paddle
10. Insert the new paddle into the chuck.
11. Tighten the chuck by hand.

TROUBLESHOOTING

For technical support, contact HERO Customer Service at 800-494-4376 or customercare@hero.ca

PROBLEM	CAUSE	SOLUTION
Mix motor will not run	Carriage too high	Lower height of carriage
	Relay failed	Replace
	Carriage limit switch failed	Replace
	No bucket in place	Insert bucket
	Bucket detection switch failed	Replace
	Emergency stop switch depressed	Twist to release switch
	Timer not activated	Turn timer to desired mix time
	Motor failed	Replace
	No power to motor	Connect mixer to power source
Paddle does not spin and/or remain attached to mixer	Chuck worn or failed	Replace chuck
Carriage difficult to move up/down	Linear bearings worn	Replace

SPECIFICATIONS

Overall Dimensions (Not including Roller Conveyor)

Height	73"
Width	39"
Depth	37"
Weight	800 lbs

Electrical Rating

Voltage	230 VAC
Frequency	60 Hz
Current	20 A

Container Size Accommodation

5 Gallon	Y
----------	---